

The Vilas Neighborhood Association's purposes are enhancement of the neighborhood's residential character and attributes, and the promotion of camaraderie among the neighborhood's residents. [https://](https://www.vilasneighborhood.com)

VILASink

www.vilasneighborhood.com

President's Message *by Doug Carlson, VNA President*

IN THIS ISSUE

- Solar energy 2
- Housing 3
- Spring things..... 4
- Food 6
- Zoo 7
- Bear Mound 8
- The VNA logo 9
- Neighborhood signs 10
- Arts 11
- Neighbors 12

Well... that was a short winter! For those who hate the long cold stretches: Whew! For those of us who love to skate at Vilas: Boo!

Like the changing of the seasons, the VNA carries on through a transition of great volunteers who help with administration, communication, and many activities & special events.

Of urgent need is a group of neighbors to host the annual Vilas Block Party on June 8. The 1900 block of Jefferson has done a phenomenal job over many years and is now passing the baton. Fortunately, they're available to share their institutional knowledge but we'll need a new group to coordinate and host. If you and a few neighbors are interested, please contact the VNA Social Chair, Bethany Nelson, at socialchairvilas@gmail.com.

There are several initiatives underway by

Vilas Council members and volunteers, and we'll pass around information and updates as those emerge. We are also tracking some potential zoning changes that could impact our neighborhood. Please tune into the monthly VNA meetings, check the meeting minutes, and read the weekly Good Neighbor Digest distributed via the Vilas listserv to keep up with the latest. See instructions for joining the listserv on the last page.

We look forward to seeing neighbors emerging from our brief hibernation and welcoming the warmer weather, the sprouting flowers, and buds on the trees. Please take the opportunity to get out and enjoy the spring beauty around the neighborhood, re-connect with neighbors under the warm sun, and patronize the many businesses in our vibrant neighborhood. ♦

All issues of the newsletter can be seen at <https://www.vilasneighborhood.com/vilasink>

February flowers in the Vilas neighborhood.





COUNCIL MEMBERS

Doug Carlson, President
1018 Oakland Avenue
vnapresident@gmail.com

Rachel Bennett, Treasurer
1119 Van Buren Street
cashdollarb@gmail.com

Tommy Johnson, Secretary
1015 Oakland Ave.
johntho1286@gmail.com

Leon Maurer
1611 Madison Street
leon.maurer@gmail.com

Lee Lazar
1906 Vilas Avenue
cyborglenis@yahoo.com

Chris Conrad
2115 Adams St.
chris@conraddevelopment.com

Bonnie Gruber
1430 Drake Street
bonniegruber@mac.com

Mike Rewey
1921 Jefferson Street
pschecke@yahoo.com

2023 COMMITTEE CHAIRS

Eileen Thompson, *Bear Mound Park*
eileenlittleredt@gmail.com

Shawn Doherty & Craig Stanley,
Edgewood Neighborhood Liaisons
shawnd7777@aol.com
craig@broadwing-advisors.com

Wendy Fearnside and Ben Biltz,
Zoning
wendy.fearnside@att.net
bpbiltz@uwalumni.com

Doug Carlson, *Joint Campus*
dcarlson5dc@aim.com

Mary Clare Murphy, *Membership*
maryclarem@charter.net

Bethany Nelson, *Social*
bethanynelsonjd@yahoo.com

Bonnie Gruber, *Newsletter Editor*
bonniegruber@mac.com

Leon Maurer, *Webmaster*
leon.maurer@gmail.com

Submission information for articles and advertising

Vilas Ink, with its circulation of 700 plus, is published quarterly for all residents of the Vilas Neighborhood. We welcome submissions, in particular letters, discussions of local issues, or services that might be of neighborhood interest. Deadline for the next issue is May 24, 2024. Please contact Bonnie Gruber for advertising availability. E-mail: bonniegruber@mac.com. For 2024 we offer five ad sizes, ranging from 1/16 page (\$35 per issue or \$125 per year) to 1/4 page (\$100 per issue or \$360 per year).

More Solar Serving MGE Customers

From Madison Gas and Electric Company (MGE)

MGE's energy supply mix is transitioning toward greater use of renewable resources as we target carbon emissions reductions of at least 80% by 2030 and net-zero carbon electricity by 2050.

Badger Hollow Solar Farm

In late 2023, the second 150-megawatt (MW) phase of Wisconsin's largest solar project began serving MGE electric customers. MGE owns a total 100 MW of the 300-MW Badger Hollow Solar Farm in Iowa County. The first phase came online in late 2021. MGE's share of the entire facility is expected to generate enough electricity to power about 30,000 households.

The completion of Badger Hollow is another step in MGE's ongoing transition toward greater use of cost-effective, carbon-free energy. By 2030, we expect every MGE electric customer will have 80% fewer carbon emissions from their electricity use simply by being an MGE customer as we work toward our goal of net-zero carbon electricity.

Tyto Solar in Fitchburg

Tyto Solar is MGE's latest solar project, expected online in early 2024. The 6-MW array in Fitchburg is a distributed energy resource, like our other Madison-area solar projects. This means it is connected directly to MGE's distribution system. Tyto Solar will serve all MGE electric customers.

Upcoming Solar Projects

These projects are part of a number of renewable energy projects to help MGE achieve our industry-leading carbon reduction goals. MGE will own a share of these three large-scale solar energy projects under construction:

- Paris Solar-Battery Park – MGE will own 20 MW of solar capacity and 11 MW of battery storage at this project in the town of Paris in Kenosha County. It is expected online in 2024.
- Darien Solar Energy Center – MGE will own 25 MW of solar capacity at this project in the town of Bradford in Rock County and the town of Darien in Walworth County. It is expected online this year.
- Koshkonong Solar Energy Center – MGE will own 30 MW of solar energy from this facility to be located in the towns of Christiana and Deerfield in Dane County. The Koshkonong facility is expected online in 2026.

Learn more about our renewable projects, energy efficiency and new technologies at mge2050.com. ♦

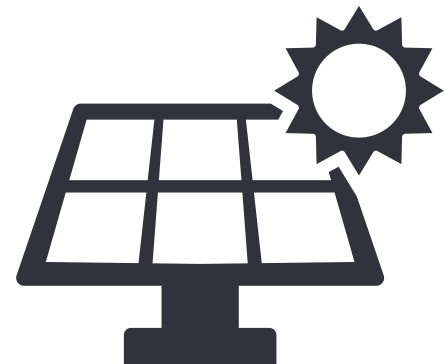

Improving Housing Access & Affordability

By Dane County Executive Joe Parisi

As the cost of housing increases, more families find themselves working extra jobs just trying to provide for their loved ones. Dane County recognizes that the cost of housing is a struggle for many and has invested in efforts to help address this issue in our community:



- In 2015, Dane County established the Affordable Housing Development Fund to encourage the development of affordable housing projects and leverage resources from project partners. So far, we have committed \$42.5 million to support projects with over 2,500 affordable living units. Another \$15 million is allocated in 2024.
- My 2020 budget created the Division of Housing Access and Affordability within Dane County Human Services. The team administers federal and county-funded partnerships with community agencies to prevent and end homelessness, increase access to and development of affordable housing, and support economic and workforce development efforts.
- During the COVID-19 pandemic, Dane County infused tens of millions of dollars in federal funding into the community to help residents cover the cost of rent and/or stay in a hotel if they were experiencing homelessness and considered at higher-risk for

severe illness from COVID-19. The programs provided stability for thousands during a truly unprecedented time.

- Joining Forces for Families (JFF) involves social workers who manage offices in neighborhoods throughout Dane County and provide direct access to services. Housing is the number one issue JFF encounters. The work staff do is time intensive and tailored to each individual. I recently added another housing specialist within JFF at a cost of \$91,700 to improve access to this vital service.
- To learn more about our efforts, check out The Dane County Podcast episode “Housing Access & Affordability” on YouTube of wherever you listen to your podcasts.

If you know someone who needs help finding housing or is struggling to keep up with housing costs, have them contact 211 Wisconsin. Our partners at Urban Triage, Community Action Coalition, Tenant Resource Center, and Homeless Services Consortium of Dane County provide vital services to Dane County residents and are all committed to increasing housing access and affordability.



Habitat for Humanity volunteers and professional builders worked side by side on a new house.

The advertisement features a portable electric space heater with a power cord that is plugged into a wall outlet. The cord is drawn out and loops around to form a dollar sign (\$). The heater is shown against a background of horizontal lines, suggesting a graph or a scale. Below the image, the text reads "plug and pay".

plug and pay

Using a portable electric space heater is one of the most expensive ways to heat your home. At today's prices, electric heat costs five times more per BTU than natural gas.

You will not save money with an electric space heater unless you turn your central heating system down many degrees and use the space heater to warm a small area.

Questions? Visit: mgoe.com/heater

mgoe
your community energy company

GS1759 1/29/2024

Spring Things in Vilas Neighborhood

Friday-Saturday, March 1-2: Musical, West High School.

Saturday, March 2, 2 p.m.: Edgewood Theatre production, "The Musical of Musicals," Diane Ballweg Theatre, the Stream Building



We may get snow again in March.

Sunday, March 10: Daylight Savings time begins.

Monday-Friday, March 11-15: Spring break, Edgewood College

Wednesday-Sunday, March 13-17, 7:30 p.m.

Wednesday, 7 p.m. Thursday-Saturday, 2 p.m.

Saturday-Sunday: Mary Poppins musical, Edgewood High School

Friday-Saturday, March 15-16: Strings Festival, West High School.

Sunday, March 17: Saint Patrick's Day

Tuesday, March 19, 7 p.m.: Choir concert, West High School.

Wednesday-Thursday, March 20-21: Naw Ruz (Baha'i holiday)

Saturday, March 23, 7 p.m.: Edgewood Chamber Orchestra concert, McKinley Performing Arts Center

Sunday, March 24: Palm Sunday (Christian holiday)

Monday, March 25: Holi (Hindu festival)

Monday-Friday, March 25-29: Spring break, Madison public schools, University of Wisconsin-Madison, Edgewood High School

Friday-Monday, March 29-April 1: Easter break, Edgewood College

Sunday March 31: Easter (Christian holiday)

Monday, April 1: April Fool's Day

Tuesday, April 2: Spring Election

Election held on the first Tuesday in April to elect judicial, educational, and municipal officers, and non-partisan county officers, and to express preferences for the person to be the presidential candidate for each party in presidential election years. State Statute 5.02(21)

Tuesday-Wednesday, April 9-10: Eid al-Fitr (Islamic holiday)

Wednesday, April 10, 6:30 p.m.: Vilas Neighborhood Association Council meeting

Friday, April 12: No school, (Madison public elementary schools)

Monday, April 15: Income taxes due. No school (Madison public schools).



Liverwort (Hepatica) blooms in April.

Wednesday, April 17, 7 p.m.: Orchestra concert, West High School

Saturday, April 20, 10 am. - noon: Earth Day Challenge, Vilas Park and Beach. <https://www.cityofmadison.com/parks/events/earth-day-challenge-2024>

Monday, April 22: Earth Day

Monday-Tuesday, April 22-30: Passover (Jewish holiday)

Wednesday, April 24, 7 p.m.: Band concert, West High School

Sunday, April 28, 2 p.m.: Edgewood College Concert Band concert, McKinley Performing Arts Center

Friday, May 3: Last day of classes, UW-Madison and Edgewood College. 7 p.m.: Concert by Choirs and Edgewood Chamber Orchestra, McKinley Performing Arts Center.

Saturday, May 4: Party for the Planet, Henry Vilas Zoo

Sunday, May 5: Cinco de Mayo (Mexican holiday), Easter (Orthodox Christian holiday); Opening day of the Monroe Street Farmers Market, Edgewood High School parking lot.

Friday, May 10, 5:30 p.m.: UW-Madison Commencement (doctoral and medical professional), Kohl Center

Saturday, May 11, 9 a.m.: Edgewood College commencement liturgy, St. Joseph Chapel. Noon: UW-Madison bachelor's, and law degree commencement, Camp ; Edgewood College undergraduate commencement ceremonies.

Sunday, May 12: Mother's Day



May apple isn't really an apple. but it does bloom in May.

Continued on next page

More Spring Things

Continued from previous page

Monday, May 13: Summer sessions begin, Edgewood College

Friday-Thursday, May 17-23: Fine Arts Week, West High School

Monday, May 20: Summer sessions begin, UW-Madison

Wednesday, May 22, 6:30 p.m.: Vilas Neighborhood Association Council meeting

Friday, May 24: No school, Madison public schools. Graduation, Edgewood High School

Monday, May 27: Memorial Day (holiday)

Tuesday, May 28: Ascension of Bah'u'llah (Baha'i holiday)

Thursday, June 6: Last day of school (Madison public schools)

Saturday, June 8: West High School graduation

Friday, June 14: Flag Day

Sunday, June 16: Father's Day

Sunday-Monday, June 16-17: Eid al-Adha (Islamic holiday)

Monday, June 17: Summer school starts, West High School.

Wednesday, June 19: Juneteenth Day (holiday commemorating the end of slavery)

Friday, June 21: Summer begins. Make Music Madison.



Fleabane blooms in June.



3518 Monroe St.
Madison, WI 53711
ph. 608-236-4570
Lakeviewvetclinic.com

Compassionate care right in your neighborhood.

Also see library events, <https://www.madisonpubliclibrary.org/locations/monroe-street-library> and Arboretum events, <https://arboretum.wisc.edu/visit/events/> ♦



It's all about working together



DR. BENJAMIN FARROW D.D.S.
DR. ALYSHA ROLLI D.M.D.

MORE INFO AT MONROESTREETFAMILYDENTAL.COM
2702 Monroe Street • Madison, Wisconsin 53711

SPANISH IMMERSION EARLY LEARNING PROGRAM





- Intercultural Learning
- Locally Owned
- Natural & Organic Foods
- Community Focused

NOW ENROLLING 6 WEEKS TO 5 YEARS
6 Odana Ct., Madison, WI 53719
(608) 690-3590
casaeearlylearning.com



Monroe Street Farmers Market Opening on Sunday, May 5

The Monroe Street Farmers Market is coming back for another season of freshness, community, and fun!

Since its inception in 2015, the Monroe Street Farmers Market in Edgewood High School's parking lot, this vibrant market has become a beloved weekly gathering for locals seeking the best of southern Wisconsin's bounty.

With between 30 and 40 farmers, producers, and artisans setting up shop each week, there's always something new and delightful to discover, from crisp vegetables to artisanal cheeses, from handmade crafts to unique local delicacies.

But the Monroe Street Farmers Market isn't just about shopping—it's about community. Run by a dedicated group of market vendors and

neighbors, the market aims to create a welcoming space where neighbors can come together to connect, chat, and enjoy each other's company.

Local musicians add a sound track to your shopping experience. There are kids' activities and other fun events throughout the summer.

If you are interested in supporting the market by sponsoring, volunteering, selling, hosting a community booth, or leading a special activity, please visit the website monroestreetfarmersmarket.org or email manager@monroestreetfarmersmarket.org.



Lallande
Madison

1859 Monroe Street
Wednesday-Saturday 4pm-10pm
lallandemadison.com



**NEW MORNING
NURSERY SCHOOL**



NOW ENROLLING

Child-centered programs with an emphasis on social development

Toddler--Preschool--MMSD 4K

For more information, visit newmorningtonurseryschool.org

Regent Mart
AND CAFE
RANDALL AVENUE AND REGENT STREET

NEIGHBORHOOD GROCERY STORE

- Indian Groceries
- Fresh produce
- Deli
- Bubble Tea shop
- Cafe



LOCAL ETHNIC RESTAURANTS'



HOT AND COLD FOOD AVAILABLE DAILY .

INDIAN, JAMAICAN AND AMERICAN HOT FOODS AVAILABLE EVERY DAY.

BEER, WINES AND BAKERY ITEMS

ONE & ONLY
SEASONAL AMERICAN BISTRO & BAR



DINNER
MON-FRI:
4PM-10PM
SAT & SUN:
3PM-10PM

BRUNCH
SATURDAY
&
SUNDAY:
10AM-2PM

HAPPY HOUR
MON-FRI : 4PM-6PM

1923 MONROE STREET
(608)285-5529
ONEANDONLYWI.COM

Henry Vilas Zoo Party for the Planet will be May 4

Party for the Planet is Henry Vilas Zoo's annual Earth Day celebration. On Saturday, May 4, the zoo, Wisconsin Department of Natural Resources, and Dane County Regional Arborists Group will celebrate the planet through a variety of activities related to sustainability and resource conservation.



Past events have featured education about green energy, a free Earth Day activity book, free tree saplings to plant at home, a Kid's Climb hosted by the Madison Arborists, and thumbprint pledges to encourage small actions that make a big difference. This year they'll also be hosting a planting party for the new kids' garden at the zoo.

Full Schedule Of Events

All Day: Self-Guided Scavenger Hunt – Start at the gate near Randall Avenue and Drake Street and find all the animals who want to teach you some wet and wild facts!

All Day: Spring Enrichment – The zoo will be giving spring enrichment to its animals all day. Explore the Zoo to see the animals interacting with various spring-themed enrichment!

While Supplies Last: Tree Sapling Giveaway – There will be a selection of native tree and shrub saplings for you to take home and plant.

While Supplies Last: Bat Stuffie Adoption – check out the “Bat Cave” at the main Tent in the center of the zoo and bring home a new friend! All proceeds go to Bat Conservation International.

10 a.m. – 2 p.m.: Tree Climbing – Join Dane County arborists and see how high you can climb! Staging area will be between our North American porcupine exhibit and the Main Tent in the center of the Zoo.

10 a.m. – 2 p.m. Planting Party – Join the zoo horticulturist and garden volunteers to help create a new kids' garden, just up the hill from the Aviary.

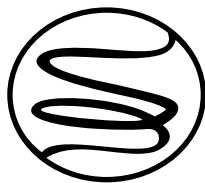

SPRING
Pilates for Life

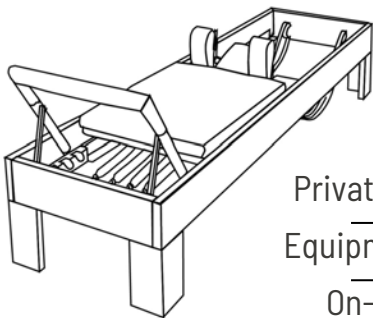

Private & Duet Sessions
Equipment & Mat Classes
On-Demand Videos

INQUIRE TODAY:

- 📍 710 Harrison St. Madison, WI
- ☎ 608-709-1775
- 🌐 springpilates.life
- ✉ info@springpilates_life



Tree House
Arbor Science

Ask your trees about us

TreeHouseArborScience.com

(608) 234-5935

Madison, WI

“Tree’t me to Life” Grows into Bear Mound Master Plan

By Eileen H. Thompson

As discussed in the winter *Vilas Ink* newsletter (<https://www.vilasneighborhood.com/vilasink>) the City of Madison had long designated the Bear Mound effigy area as a traffic circle. This classification provided little directive or safeguards toward the protection of this area, which has historical and cultural significance to the Ho-Chunk Nation.

In 1995, several Vilas neighborhood residents began a three-year long effort to save two old Oaks from removal; of particular interest was a Native American Marker tree. These efforts led to the formation of the Vilas Circle Committee who developed a more comprehensive long-term plan for managing the area. The committee consulted with UW Botanists, UW Arboretum specialists, a Department of Natural Resources savanna expert, City of Madison Parks personnel and risk manager, Native Americans, and various individuals with pertinent knowledge to develop a Master Plan document (40+ pages).

The Vilas Neighborhood Association Council approved Plan “A” November 19, 1997, and provided an informational tour that December. Finally, in January of 1998 the Vilas Circle Master Plan was approved by the City of Madison Parks Commission with the new designation as a culturally significant park. .

The plan addressed all issues, options, and recommendations pertaining to Vilas Circle. Here is a short summary:

Archeological and Cultural Values

In reference to the Bear effigy, the Marker tree and identified burial mound, and equinox rock: City to enforce small hand mower use, defer to Ho-Chunk Nation’s preference to managing the mounds, allow the Marker tree to live out its natural life, remove a maple obscuring the line of equinox rocks.

Trees

Designate and maintain a mix of both open (sunny) and wooded (beneath tree canopy) areas in the park. Areas for open-grown old oaks – south and east ends. Remove shade- tolerant trees that are now threatening the health of these oaks (basswood/ lindens, ash, cherry, maple). Replace plantings with white and bur oak seedlings or older oaks. The approved plan called for removal of these trees: four less than one ft. diameter, 11 one to two ft. diameter and nine greater than two ft. diameter.

Ground Cover

Reduce mowing cycle to a 20-day cycle, put topsoil over exposed tree roots, and seed the areas. In May-June 1998, do not mow to inventory for native savanna plants. Then, establish an experimental “natural area” on the south-west edge. Limit the use of large trucks on soil.

Public Safety and Liability Concerns

Remove fence (orange fencing placed around Oak trees that originally were to be removed), and work with city officials to determine appropriate signs to reduce city’s risk of limbs falling. Neighbors may prefer posting a risk for entire park. City risk manager wants to only label the “Marker Tree” as being at risk, thus all trees determined hazard can be removed at their discretion (update: ultimately sign deemed unnecessary).

Donated Plantings

Remove or move most donated plantings, replace some donated plantings with new trees more appropriate to the park, acceptable to the families. Promote alternative donations (monetary) and restrict future plantings.

Continued on next page

COME VISIT ORANGE TREE IMPORTS
Voted Madison's Best Gift Shop Over 30 Times



- Cookware
- Toys & puzzles
- Wisconsin gifts
- Soaps & candles
- Greeting cards
- Food & candy
- Seasonal decor
- Kitchen tools
- Unique jewelry
- Polish Pottery
- Wedding Registry

1721 MONROE STREET • ORANGETREEIMPORTS.COM
Family Owned Since 1975

EST.  2013

MYSTERY TO ME
an independent bookstore

We're more than mystery! Shop new releases, fiction, non-fiction, poetry, children's, and of course, mystery books.

1863 Monroe Street, Madison WI
mysterytomebooks.com

Tue-Fri: 10am – 6pm
Sat: 10am – 5pm
Sun: 10am – 4pm

About VNA's Logo

We've been asked why the Vilas Neighborhood Association logo, on the cover of this newsletter, says "Est. 1892." Did VNA really exist in 1892?

The 1892 date refers to the formation of VNA's first predecessor, the Wingra Park Advancement Association, which filed its articles of association with the state on October 31, 1893.

The organization changed names and boundaries several times, but has kept the current name and boundaries since 1992.

The logo was created in 1997 by Vera Abing. In introducing it, Chuck Erickson explained:

"The basis of the logo consists of the circle park located at the intersection of Vilas and Campbell. We chose this layout because the circle park is a distinctive feature of the

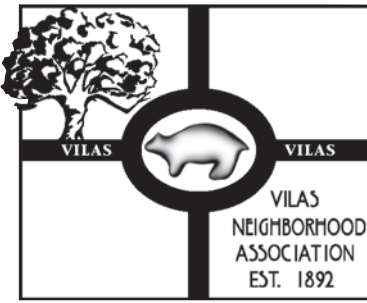

Vilas neighborhood. The components include a tree, representing the Native American marker trees in the park and neighborhood. It also represents the large number of trees in the neighborhood and in Vilas Park. The bear depicts the actual effigy mound which existed on this site and also represents the bears and other animals in the Henry Vilas Zoo, adjacent to the neighborhood.

"Finally, the font represents one of the architectural styles found in the neighborhood," Erickson wrote.

Bear Mound Park

Continued from previous page

Recreational Uses

Plans should not interfere with traditional use areas, create trails, and maintain designated open sunny areas.

Neighborhood Involvement and Volunteer Support

Establish a natural area as a five-year experiment; start small with neighbor volunteer involvement.

Park Designation, Signs, Interpretation

Designate the park as a "Special Facility" park with culturally significant value called Vilas Circle Park. (Update: The name was changed to Bear Mound Park chosen by late Virginia Heimerl, long-time resident.)

Erosion Control

Work with Parks staff to develop a hardy ground cover to plant in the worst areas of erosion; this could include re-seeding and/or fertilizing grass. Add stones to shore up eroding slopes on the southwest corner.

The development and implementation of this Vilas Circle Master Plan has led to preservation of our oldest neighborhood residents in Vilas, the stately oaks, on what is now known as Bear Mound Park. Several other neighborhood projects have resulted from the plan including restoration of an Oak Savanna and Prairie on the edges of the Park and planting of white oak saplings.

Vilas Neighborhood Association expresses a big thank you to everyone who has been involved in all the various stages of the long but rewarding process.

TORN EDGE ARTS Metalsmith Studio

Offering CLASSES in jewelry making, metalsmithing, and stained glass to all interested adults.

Date night? Friends night out? New hobby? Forever bracelets? Repairs? YES!

Feed Your Fire!

1639 Monroe St.
www.tornedgearts.com
Sue Moberly
608-698-7644



Sign up for classes online, or call with questions.

MONROE STREET FRAMING

◆ SINCE 1983 ◆

- Custom framing
- Installation
- Consultation
- Restoration
- Corporate services

OPEN
Tues – Sat, 10am – 5pm
Walk-in or by appointment

1901 Monroe St, Madison
608.255.7330
monroestreeframing.com



Association Seeks Grant to Restore Neighborhood Signs

The Vilas Neighborhood Association has applied for a City of Madison Neighborhood Grant to replace the broken welcome sign at Regent Street and Randall Avenue and rehabilitate two similar signs.

VNA wants to replace the broken sign with a durable high-density urethane (HDU) sign for a cost of about \$2,500. Ald Tag Evers and a co-owner of the adjacent Regent Mart, Meenu Kaushal, have written letters of support

Neighborhood volunteers will do the substantial cleaning, and preserving of the other two signs, at Adams and Campbell and at Grant and Drake streets.

"We anticipate participation of volunteers of all ages and all parts of our neighborhood for cleaning, painting, and preserving the signs and maintaining the signs and foliage around the signs on an ongoing basis," said VNA President Doug Carlson.



This is the broken sign which Vilas Neighborhood Association would replace with help of a \$2,500 city grant. The upper part of the oval artwork is missing.



This sign at Adams and Campbell streets and one like it at Grant and Drake still have the full oval picture of a bridge and waterfowl. They need some paint.

hive
OF MADISON

A locally owned
outdoor lifestyle boutique

Featuring men's and women's clothing, footwear, gifts, and accessories from Patagonia, Toad&Co, DUER, Smartwool, prAna, Vuori, Fjallraven, Chaco, Birkenstock, On Running, and many more.

Sunday 11-5
Monday-Friday 11-6
Saturday 10-5

Conveniently located
across the street from Trader Joe's

1904 Monroe Street
Madison, WI 53711
608.467.2410
www.hiveofmadison.com

Edgewood Campus School

**SPOTS OPEN IN
5K AND 1ST
GRADE!**

IF INTERESTED, EMAIL SALLY DREA
AT SLDREA@EDGEWOODK8.COM
OR CALL AT 608-663-4126.

Make Music Madison 2024

Make Music Madison (MMM) will return Friday, June 21, 2024. Coffee shops, restaurants, front porches, and parks across Madison, including Vilas neighborhood, will fill with music for anyone to enjoy.

MMM is a free, citywide, outdoor day of music held annually on the summer solstice. Initiated in Madison in 2013, our festival is part of the larger Make Music Day, an international summer solstice music celebration occurring in 1,000+ cities across the globe.

MMM is:

- Performed by anyone, enjoyed by everyone.
- A way to celebrate the summer solstice, enjoy the longest day of the year, and sample a buffet of musical merriment.
- A DIY city-wide celebration when almost any way to make music can and will happen.
- Open to music makers of all ages, skill levels, and musical persuasions.

Venue registration opens March 25 and musician registration begins April 1. The MMM website, <https://www.makemusicmadison.org>, helps match musicians and venues. ♦

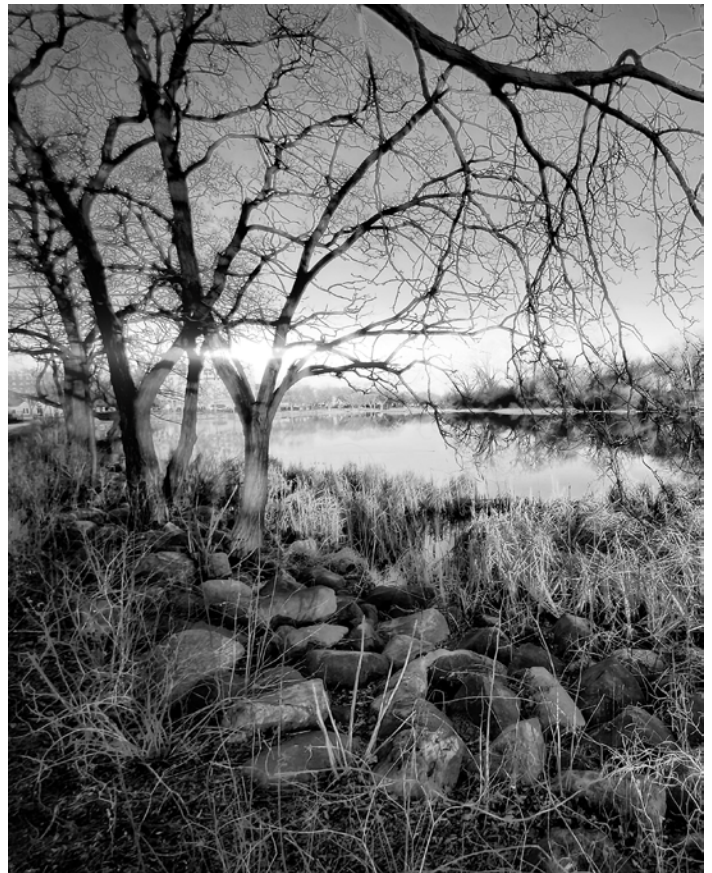

One of Tom Turnquist's many artistic photos of the Lake Wingra area.



A Different Approach To Real Estate

Our savvy team guides you through every step of the home buying and selling experience with integrity and competence. We are your neighborhood Realtors, creating diverse, sustainable, and vibrant communities together.



608.251.6600
 Info@TheAlvaradoGroup.com
 TheAlvaradoGroup.com
 1914 Monroe Street, Madison



LIVE THE POSSIBLE.

Remodels, additions and new home construction. Plan. Design. Build. We make it possible.



Christensen
 CONSTRUCTION

608.252.8406 | christensenconstruction.net

Meet Our Neighboring Neighborhoods

Follow the links or scan the codes for information about Vilas and nearby neighborhoods and their associations.

Bay Creek <http://www.baycreekmadison.org/bulletin.html>



Dudgeon-Monroe <https://www.dmna.org/hornblower-archives>



Greenbush



Regent <https://www.regentneighborhood.org/newsletter.html>



Vilas <https://www.vilasneighborhood.com/vilasink>



You can donate to the VNA via PayPal!

Suggested membership donation is:
\$20/household or
\$10/individuals

<https://www.paypal.me/VilasNA>

JOIN THE DISCUSSION

The VNA sponsors an online listserv for our members:

<https://groups.io/g/VilasNA>

You can ask to join the email list by sending an email to:

VilasNA+subscribe@groups.io

Please identify yourself by name and address to facilitate this process, since this listserv is primarily for those who live within the VNA boundaries.

 - - - - - **Renew & Join for 2024!** Annual Membership runs from January 1 - December 31 - - - - -

VNA Membership Form

Suggested membership donation is \$20/household or \$10/individual.

- I wish to renew my VNA membership (It is not necessary to fill out the form unless there are changes)
- I / we would like to contribute \$_____ to the VNA
- Add my name as a new VNA member (Please fill out the following)

Names _____

Address _____ **Telephone** _____

Children's name(s) _____

Home email address(es) _____

Year moved into VNA area _____

Make check out to Vilas Neighborhood Association and mail it to Rachel Bennett, 1119 Van Buren Street, Madison, WI 53711. Or use PayPal: <https://www.paypal.me/VilasNA>